

Mission Possible

Accounts Payable State of the Art Process

Albert Buijze

March 2019

Agenda

- Introduction
- Principles
- Current Process
- Why, How, What
- Digital World: Simplify, Transpose. Accelerate
- What's in it for Financial Control
- Lessons learned

Virtual Close

More Than Technology

The virtual close is not just a matter of rolling out new **technology**. It requires a sustained, companywide effort to redesign our **processes**

World Class Finance

How to accelerate business growth

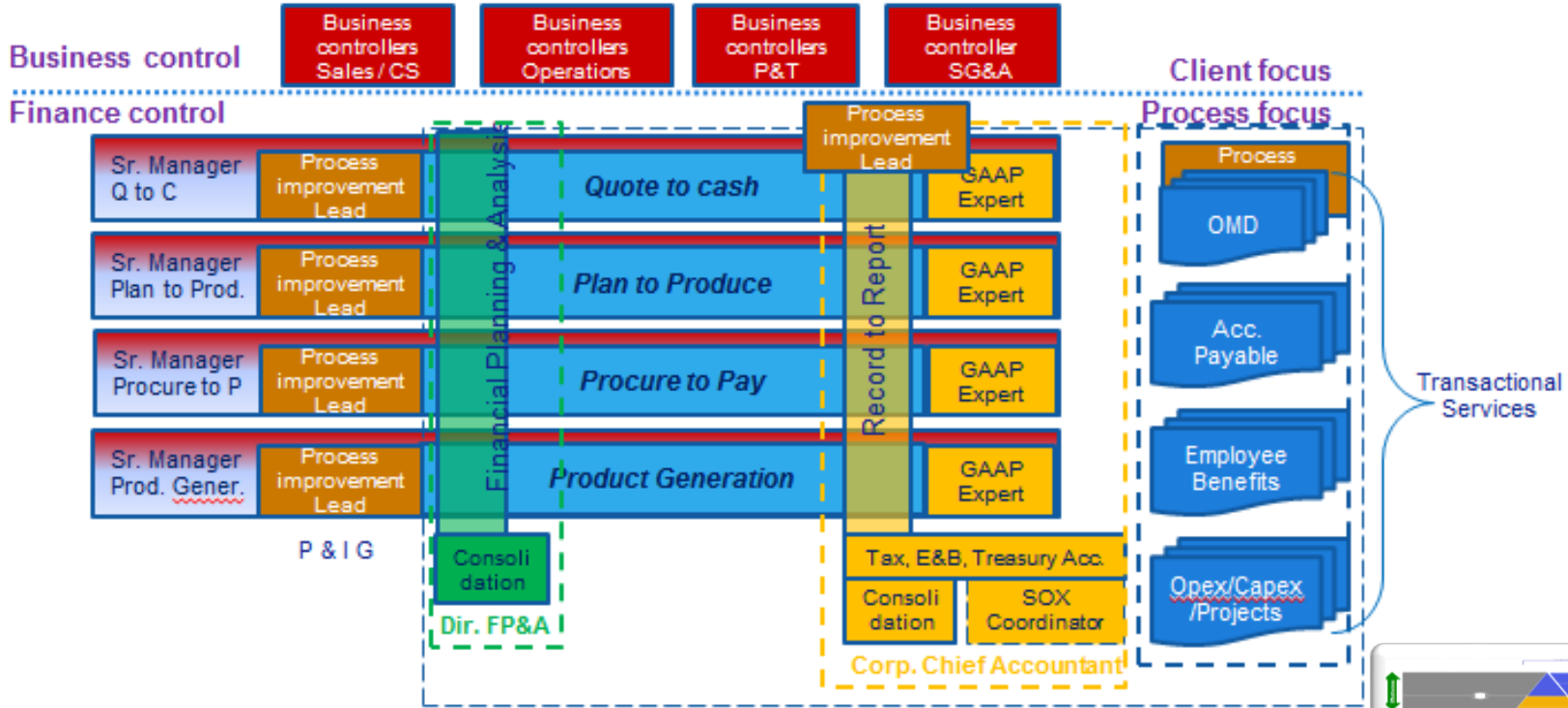

Principles – Process – Why, how, what - Digital World – Financial Control – Lessons

World Class Finance 2019

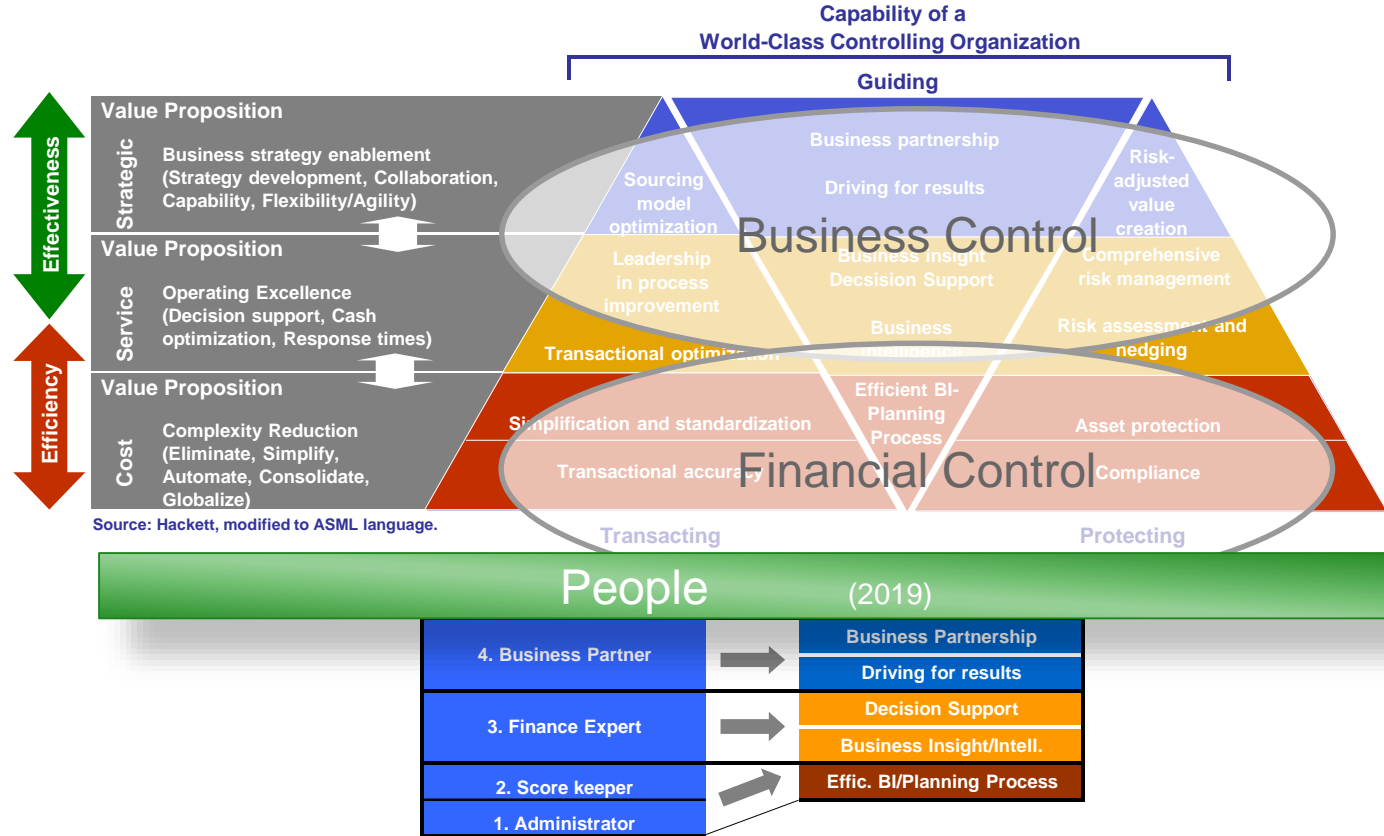

Principles – Process – Why, how, what - Digital World – Financial Control – Lessons

Accounts Payable

Public

Slide 6

18 March 2019

prepare for the **Digital-First World**

revolutions in technology, societal engagement, and enterprise operations will converge to change the way we all do business by the end of this decade

Simplify processes, **Transform** platforms, and **Accelerate** information delivery



SIMPLIFY. TRANSFORM. ACCELERATE.

Principles – Process – Why, how, what - Digital World – Financial Control – Lessons

DIGITAL : DISRUPT OR DIE

COMPETING IN A DIGITAL – FIRST WORLD

Transform your business to capitalize on digital disruption and compete in a Digital-First World.

More than a buzzword, digital is coming like a fast-moving, unstoppable train. By 2020, profitable organizations will use digital channels to discover new customers, enter new markets and tap new streams of revenue. Those that don't make the shift, could fall to the wayside.

Current Process

Accounts Payable is Posting Invoices

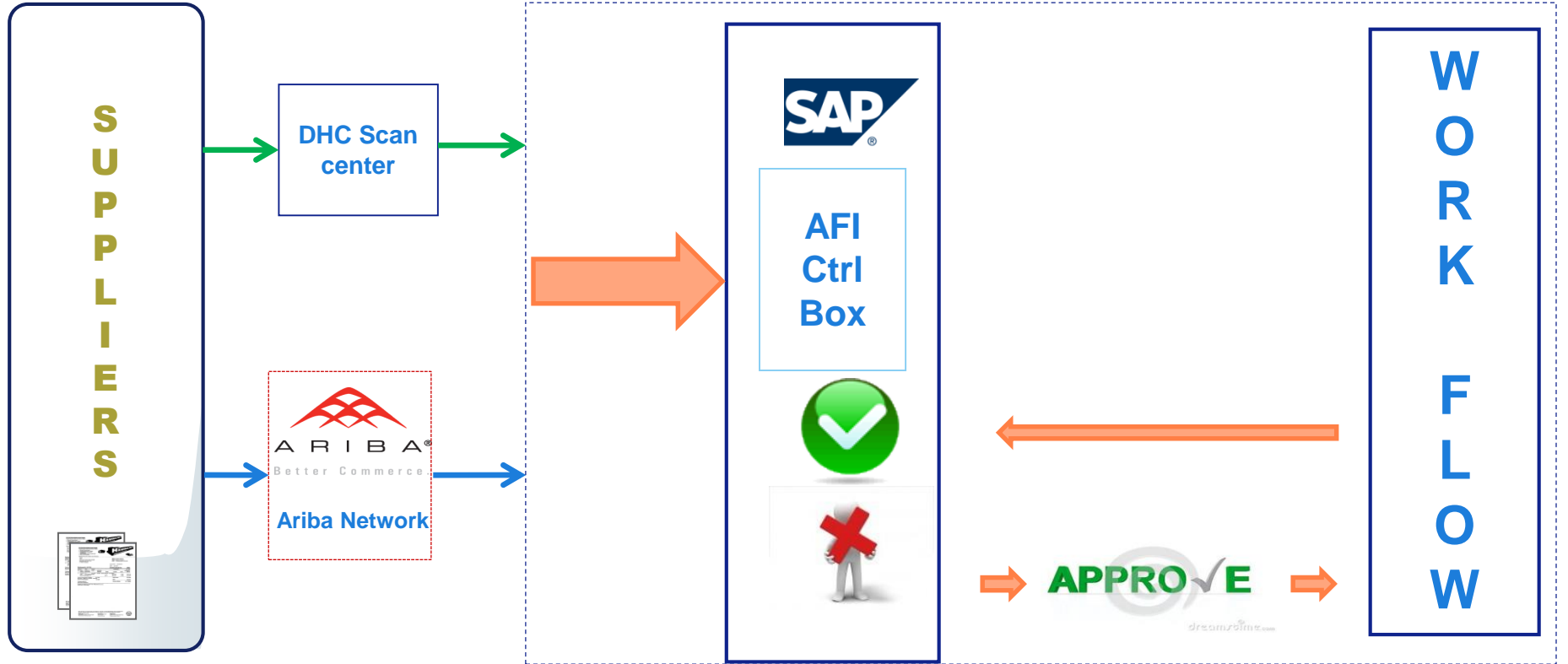

Facts & Figures 2012 & 2018

- Auto posting rate of invoices went up from 40 to 85%
 - Saving 7 FTE
 - Total FTE reduction since 2010 is 20 till now, process and automation improvements
- 58% vendors enabled (invoice volume) on Ariba Network in two years
 - More PO's, better Spend Control
 - Better quality resulted in throughput time reduction of 50%
- PR vendor enablement on the Ariba Network is 78%
- NPR vendor enablement on the Ariba Network is 75%
 - This is excluding Freight, Flex invoices and Invoices without PO
- Annual Spend 2018
 - 6.8 billion in value
 - 625.000 invoices
 - 5.500 active suppliers World Wide

From AP current Process, 85% auto posting to 100%

- Enable as much vendors on Ariba Network
 - Better quality invoices, less errors, will improve auto-posting rate
 - Only allow invoices which are 100% correct for posting, this will make Work Flow superfluous.
- Freight Invoices through Transparix, e-invoicing on Freight PO (10%)
- Auto Processing of remaining invoices without PO, like pension fund, insurance invoices etc, through Sticky Notes on invoice PDF
- Smart adjustments in P2P process (5%)

- **DIRECT POSTING FROM ARIBA NETWORK IN SAP FMO**
 - Cutting Interfaces and Maintenance Programs
 - Less IT dependent

Why, How, What

- Why
 - Transparent Vendor Invoice Posting, Stable Controlled process for all parties involved at the lowest cost
- How
 - Close Cooperation (Key) between Procurement, Finance (AP), Suppliers, IT Providers & Demand
- What
 - Transparent AP Process, Stable Controlled
 - Low Cost and Sustainable

Accounts Payable

Public

Slide 12

18 March 2019

Simplify processes, **Transform** platforms, and **Accelerate** information delivery



SIMPLIFY. TRANSFORM. ACCELERATE.

Principles – Process – Why, how, what - Digital World – Financial Control – Lessons

Simplify

- Understand P2P Chain
- Respect the stakeholders in P2P process
- Use Buckets
 - Split Spend in digestible parts
 - Create Clear Processes per bucket
 - Automate
- Posting Invoices is easier through clear process and instructions (students instead of Flex)
- Vendor Master Data Management through MDG, (later combined with Ariba Network)

Procurement to Pay Chain

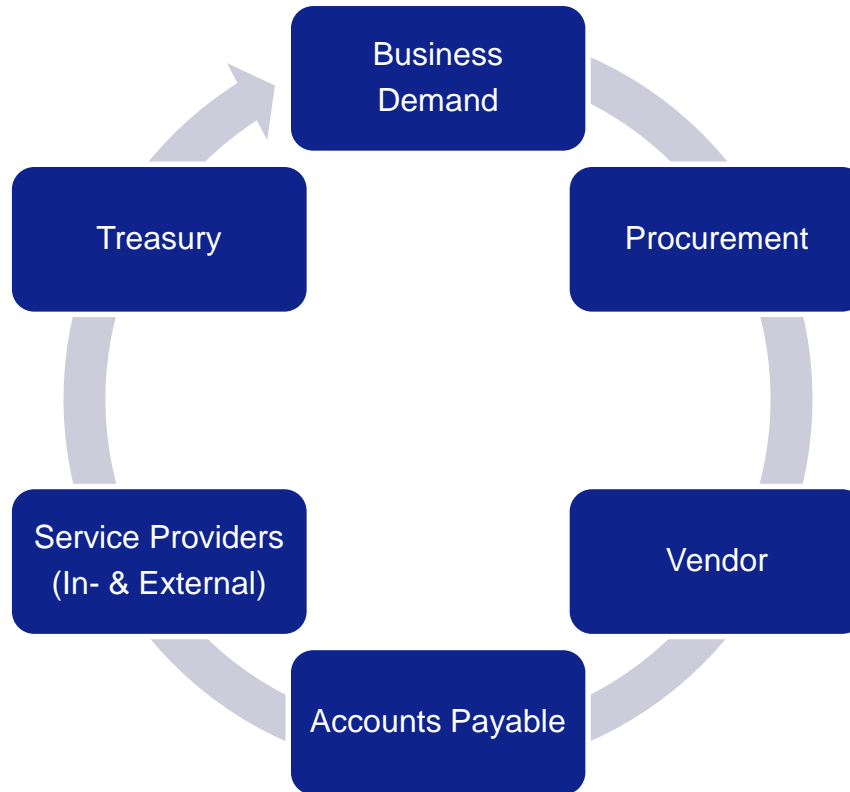

Buckets, P2P Kinds of Demand

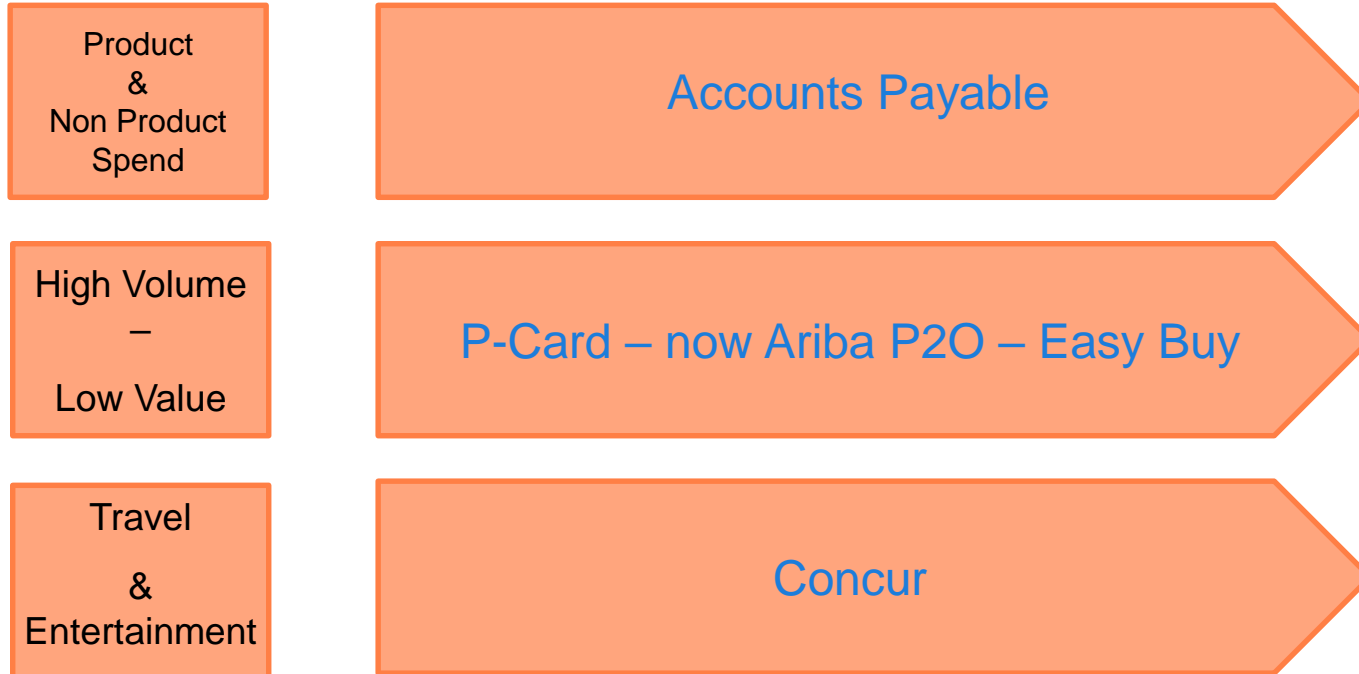

Transform

- From Manual Posting of received paper invoices to
- AFI Tool with logic and auto posting
 - Manual posting is boring and is not stable
- Paper invoices to PDF to scan center
- Ariba Network for e-invoicing, plus rules
- Students, incorrect posting rate did not change
 - More Flexibility
- Vendor Master Data Management through Ariba Network in MDG, SAP

One Source of Truth (less IT, interfaces)

- AFI software
 - All invoice related events, from invoice date to payment date, per invoice are registered in AFI
 - AFI is basis for reporting. Combined with BW and Spotfire
 - This way issues can be monitored and improved
- Software Development by AP and AFI and Ariba
- SAP, BW, Spotfire, daily automated reporting

Accelerate

- Ariba Network, e-collaboration
 - Prohibit incorrect invoices entering SAP
- Fieldglass, better Flex Process
 - Easy hiring, quality, stable process, self billing
- Transparix, Freight solution, autoposting
- EasyBuy development
 - Contract buying and PO's
 - Rent contract PO's
- Less depending on IT services
- SAP, HANA, Spotfire, daily automated reporting

Validating Electronic Invoices on the Network

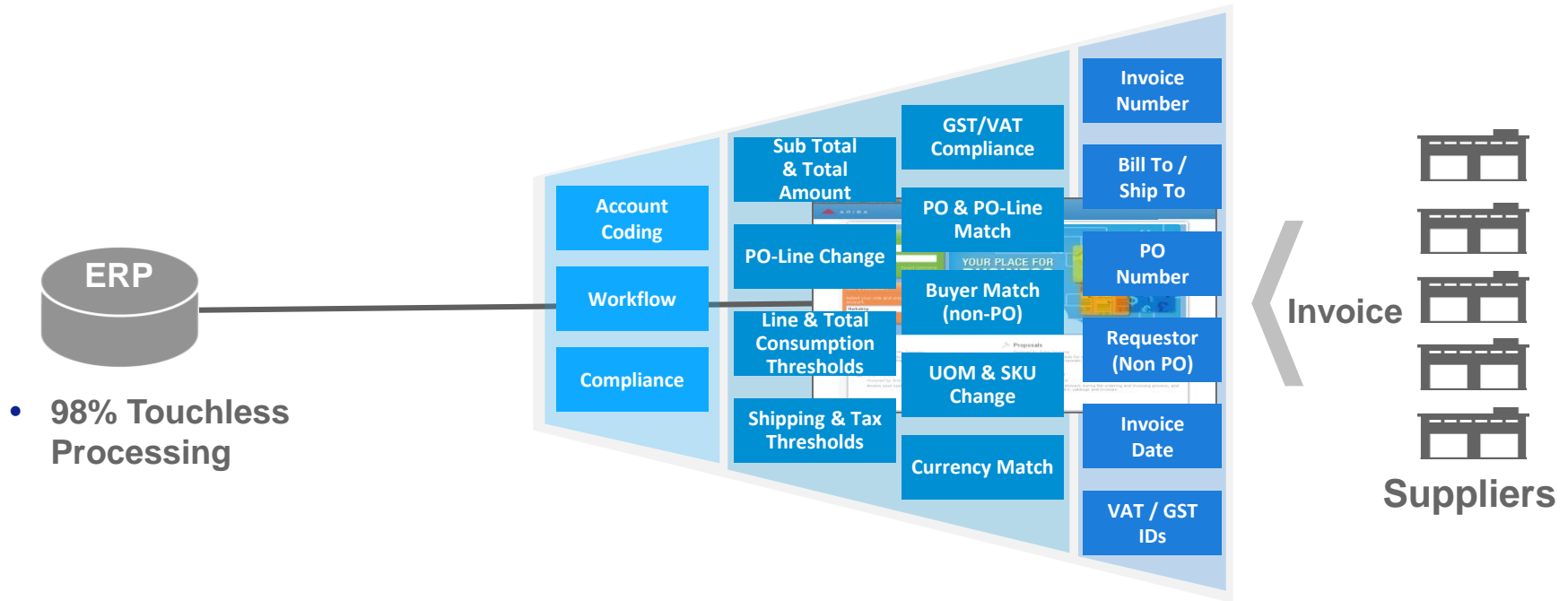

Current Process

Ariba – AFI – SAP PO- Invoice Integration

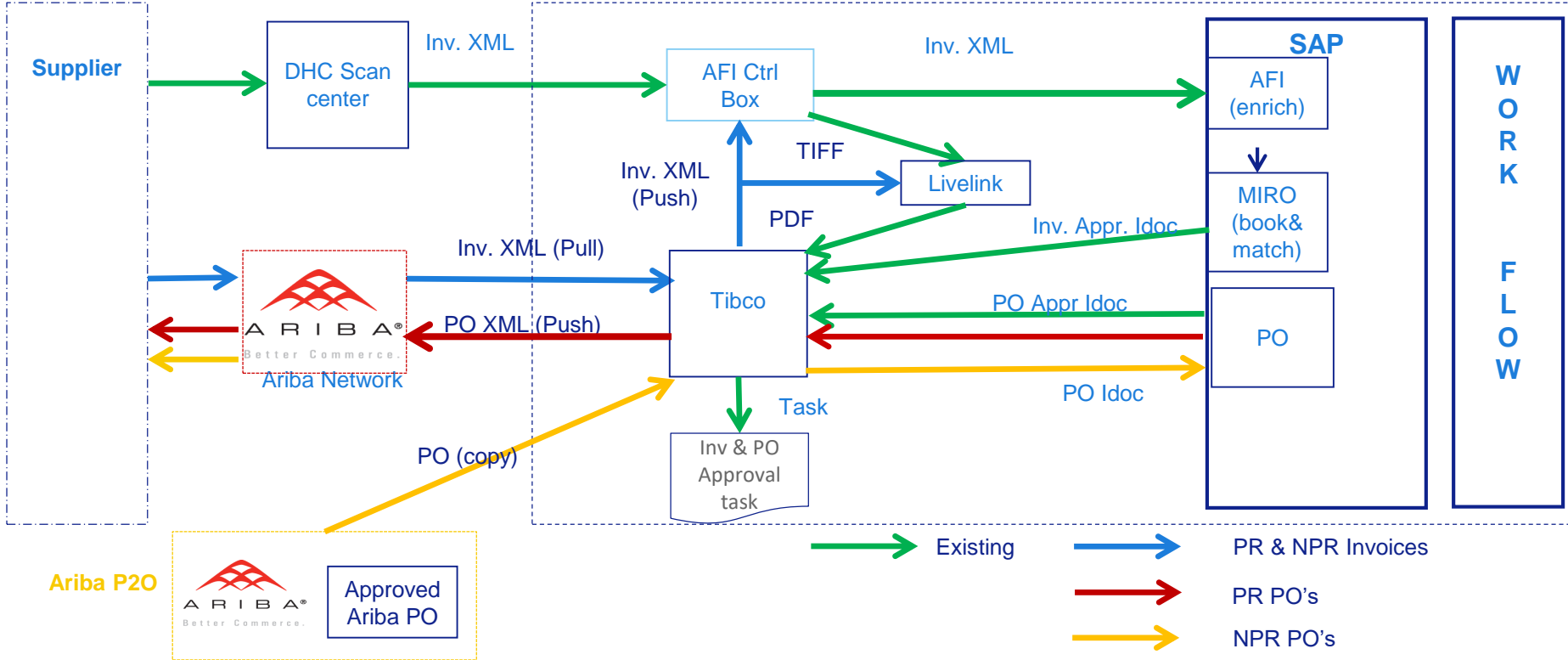

To Be Process Ariba – SAP

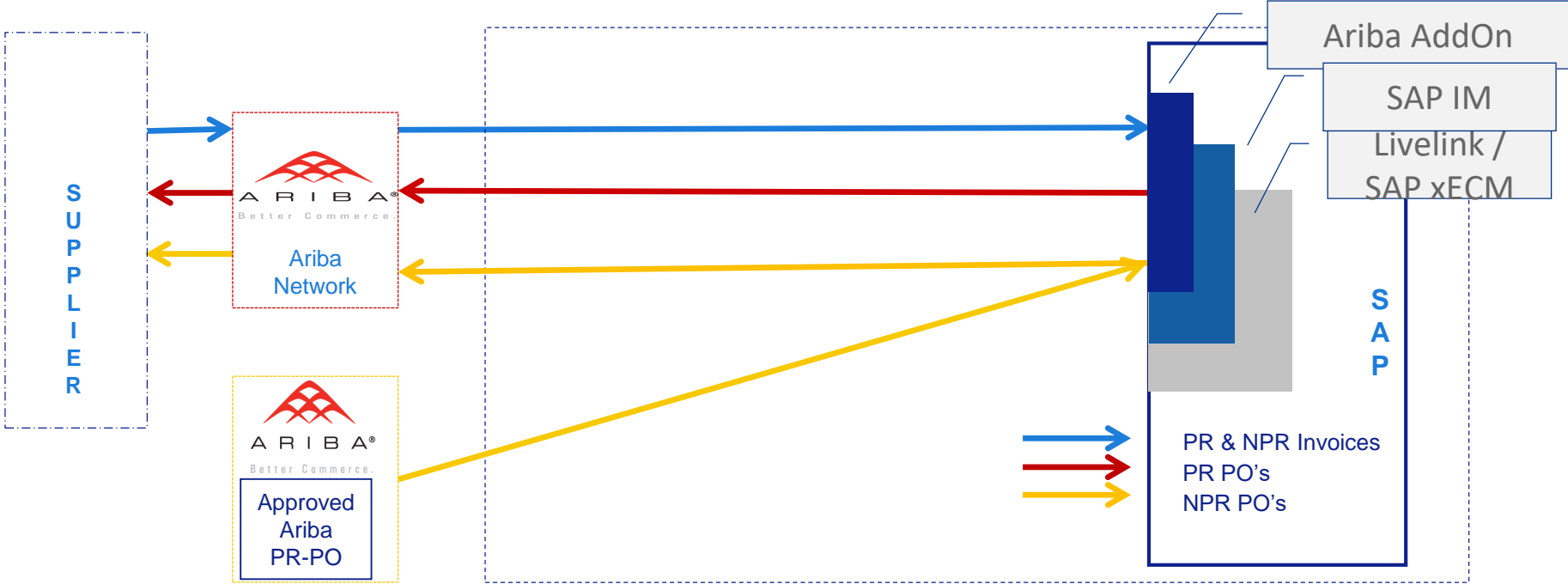

Lessons Learned

- You can only excel if you understand and work with the entire chain, in this case the P2P chain, P2P Process
- Pay Lots of Attention to Details
- Never Trust your External IT service providers
- Always ask for POC (Proof of Concept)
- Be aware of the IT “JWGWJBS” syndrome
- Internal awareness, need for change
- Vendor Awareness
- Software Development by AP, AFI and Ariba
- Involve Internal Control from day 1

Team to be Proud Of

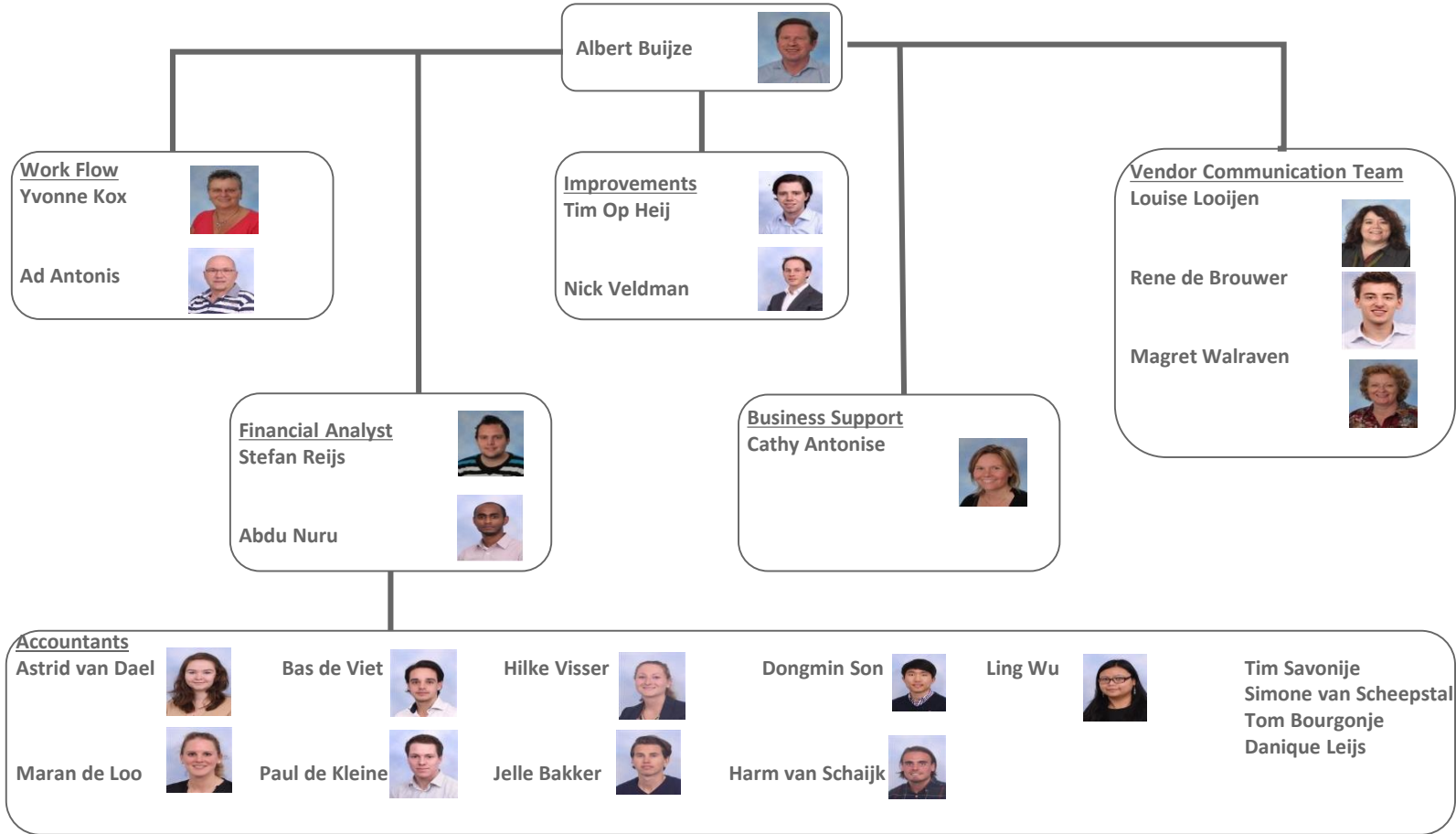

Accounts Payable

Public

Slide 25

18 March 2019

prepare for the **Digital-First World**

revolutions in technology, societal engagement, and enterprise operations will converge to change the way we all do business by the end of this decade

Simplify processes, **Transform** platforms, and **Accelerate** information delivery



SIMPLIFY. TRANSFORM. ACCELERATE.